

2W(UW) Series 2/2 Direct Drive Type Solenoid Valve(Large Aperture)

Internal structure

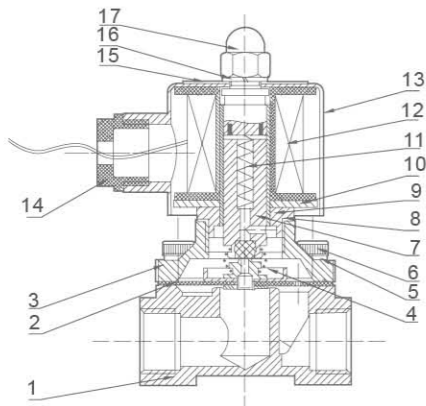

NO	Name	NO	Name
1	Body Of Valve	10	Magnetic Plate
2	Assembly Of Diaphragm	11	Spring
3	Valve Cover	12	Assembly Of Coil
4	Pull Spring	13	Iron Cover
5	Gasket	14	Cord-locks
6	Socket Hexagon Screws	15	Name Plate
7	Assembly Of Iron Core	16	Gasket
8	Seal Gasket	17	Head Cover Nut
9	Assembly Of Iron Core		

Overall Dimensions

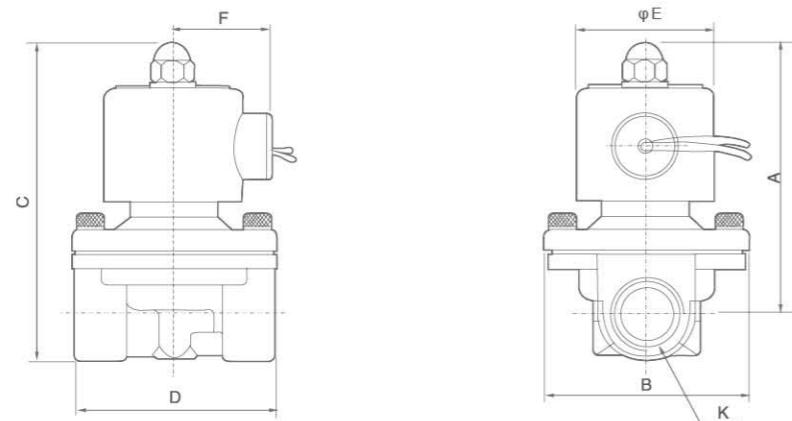

2W(Large Aperture)

Dimension Sheet

Model	A	B	C	D	E	F	K
2W160-10	101.5	57	117	67	50	36	G3/8"
2W160-15	101.5	57	117	67	50	36	G1/2"
2W200-20	107	57	123.5	72	50	36	G3/4"
2W250-25	111.5	73.5	134.5	92	50	36	G1"
2W350-35	142	95	172	125	70.5	56	G1 1/4"
2W400-40	142	95	172	125	70.5	56	G1 1/2"
2W500-50	172	123	209	168	70.5	56	G2"

2S Series Stainless Steel Solenoid Valve



Graphic Symbol

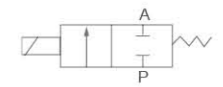

Ordering Code

2S

025

08

F

AC220V

□

Specification Code

2S:Two-position two-way solenoid valve (Stainless steel direct drive type)

Aperture of Flow Rate

025:2.5mm
040:4.0mm
160:16mm
200:20mm
250:25mm
350:35mm
400:40mm
500:50mm

Port Size

08:G1/4"
10:G3/8"
15:G1/2"
20:G3/4"
25:G1"
35:G1 1/4"
40:G1 1/2"
50:G2"

Initial Estate

Blank:Pipe Jiont type
F: Flange Type

Standard Voltage

DC12V DC24V
AC24V 50Hz/60Hz
AC36V 50Hz/60Hz
AC110V 50Hz/60Hz
AC220V 50Hz/60Hz
AC380V 50Hz/60Hz

Wiring Form

Blank:Lead Wire Type
D:Joint Connector
E:Blast-proof Coil
G:Water-proof Coil

Specification

Model	2S025-06(08)	2S040-10	2S160-10(15)	2S200-20	2S250-25	2S350-35(40)	2S500-50
Working Medium	Air,Water,Oil,Gas						
Motion Pattern	Direct Drive Type						
Type	Normal Close Type						
Aperture of Flow Rate(mm)	2.5	5	16	20	35	40	50
CV Value	0.23	0.60	4.8	7.6	24	29	48
Port Size	G1/8" G1/4"	G3/8"	G3/8" G1/2"	G3/4"	G1"	G1 1/4" G1 1/2"	G2"
Operation Fluid Viscosity	20 CST (Below)						
Working-pressure	Air:0~0.7MPa Water:0~0.5MPa, Air:0~0.7MPa, Oil:0~0.5MPa, Gas:0~0.7MPa						
Max. Pressure Resistance	1.05MPa						
Operating Temperature Range	-5~+80°C						
Voltage Range	±10%						
Material of Body	Stainless steel						
Material of Oil Seal	NBR EPDM or VITON						

Note:2S Series Solenoid Valve's Oevrrall Dimension, Flow Chart and Inner Structure all Same as 2W Series.