

### XOU Series Air Source Treatment Unit



The XOU consists of XOF and XOL, each unit can be ordered separately. The XOF with water separator cleans the compressed air of fluid oil, condensation and dirt. Particles. For special application, the standard 40µm filter element may easily be replaced by a 5µm filter element. The XOL maintains inputting constant operating pressure despite fluctuation in line pressure and the amount of air consumed. The proportional lubricator adds a regulated quantity of oil to the filtered air. The oil-mist content proportional to the flow and oil can be added during operation. The oil drop rate is controlled by the adjustable bolt. Normally, 1 to 12 drops/1000L of the air is sufficient.

Ordering Code

<b>XO</b>	<b>U</b>	<b>MINI</b>	<b>1/4</b>	<b>□</b>	<b>□</b>	<b>□</b>	<b>□</b>
<b>Series</b>	<b>Function code</b>	<b>Body</b>	<b>Port Size</b>	<b>Grade of Filtration</b>	<b>Manometer</b>	<b>Drain Type</b>	<b>Color</b>
XO Series F.R.L	Combination	MINI MIDI MAXI	G1/8" G1/2" G1/4" G3/4" G3/8" G1"	Blank:40µm 5M:5µm	Blank:12bar 7:7bar	Blank: Turnd Manually S:Half-Auto Drain Type A:Auto Drain Type	Blank:Orange BU:Bule

Specification

Model	MINI	MIDI	MAXI
Working pressure:12bar,40µm	XOU-1/8-MINI	XOU-1/4-MINI	XOU-3/8-MINI
Working pressure:7bar,40µm	XOU-1/8-7-MINI	XOU-1/4-D-7-MINI	XOU-3/8-7-MINI
Working pressure:12bar,5µm	XOU-1/8-5M-MINI	XOU-1/4-5M-MINI	XOU-3/8-5M-MINI
Manometer	0~12bar	OMA-40-16-1/8	OMA-50-16-1/4
	0~7bar	OMA-40-10-1/8	OMA-50-10-1/4
Medium	Compressed air		
Features of structure	Sintered filter with water separator;MINI/MIDI:MAXI:Piston regulator;Diaphragm type regulator;Direct constant-density lubricator		
Mounting type	Pipe mounting or foot mounting		
Assembly position	Vertical ±5°		
Connection	G1/8"	G1/4"	G3/8"
Standard nominal flow rate	XOU-...(-A)	700	1000
	XOU-...-7(-A)	800	1300
	XOU-...-5M(-A)	600	850
Primary pressure	Manual condensate drain	1~16bar	
	Automatic condensate drain	1.5~12bar	
Working pressure	0.5~12bar/0.5~7bar		
Min.Standard nominal flow rate	3 L/min	6 L/min	10 L/min
Grade of filtration	40µm/5µm		
Capacity of condensate fluid	22ml	43ml	80ml
Temperature range	0~60°C		
Materials information	Housing:Zinc die-casting;Filter bowl and oil bowl:PC;Metal bowl guard:Aluminum alloy;Sealing:NBR;Adjusting knob:POM		

Internal structure

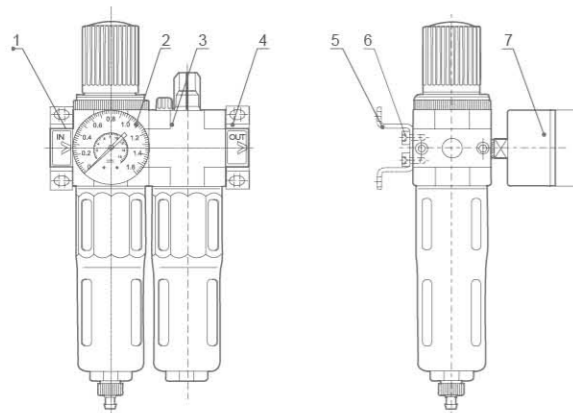

No	Name	Material
1	Flange-IN	Zinc alloy
2	Filter + Regulator	
3	Lubricator	
4	Flange - OUT	Zinc alloy
5	Bracket	SPCC
6	Allen screw	S35C
7	Pressure gauge	

### XOU Series Air Source Treatment Unit

Overall Dimensions

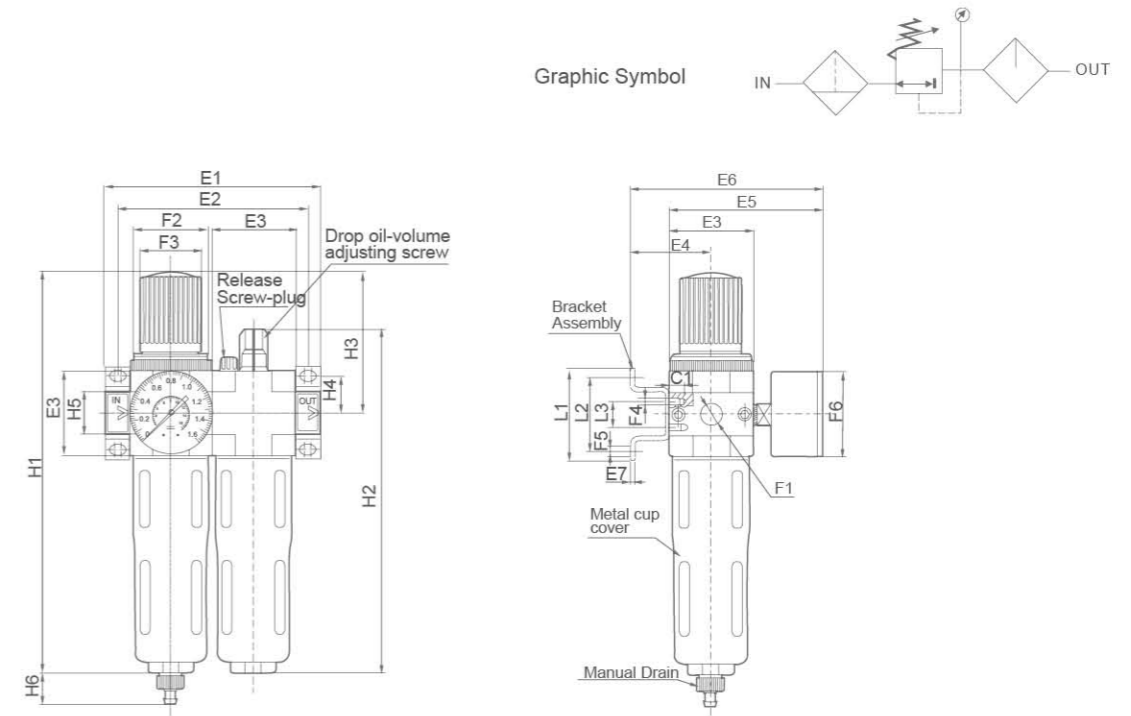

Dimension Sheet

Model	E1	E2	E3	E4	E5	E6	E7	F1	F2
XOU-...-MINI	104	92	40	39	76	95	2	G1/8",G1/4",G3/8"	M36×1.5
XOU-...-MIDI	140	125	55	47	93	112	3	G3/8",G1/2",G3/4"	M52×1.5
XOU-...-MAXI	162,182	146,157	66	53	104	124	3	G3/4",G1"	M52×1.5

Model	F3Φ	F4	F5Φ	F6Φ	L1	L2	L3	H1	H2	H3	H4	H5	H6
XOU-...-MINI	31	M4	4.5	41	44	35	11	194	169	69	17.5	20	15
XOU-...-MIDI	50	M5	5.5	352	71	60	22	250	206	97	24.5	32	15
XOU-...-MAXI	50	M5	5.5	53	71	60	22	272	226	80	24.5	32,40	15

Note: The Color Can Be Customized According to Your Requirement.

Flow diagram

Standard flow rate qn as a function of the output pressure p2

