

XHZ Series Style Air Gripper

Dimension Sheet

Bore(mm)	A	B	C	D	E	F	G	H	I	J	K	K1	K2	K3	ΦL	M	N	O	P	Q	
10	6	23	12	37.8	57	29	15.2 ^{+2.2} ₀	11.2 ⁰ _{-0.7}	4 ⁰ _{-0.1}	16	M3×0.5	6	5.5	6	2.6	27	Φ11H9 ⁰ ₀ ^{+0.043}	Dp:2	11.4	M2.5×0.45	3
16	7.5	24.5	15	42.5	67.3	38	20.9 ^{+2.2} _{0.2}	14.9 ⁰ _{-0.7}	5 ⁰ _{-0.1}	24	M4×0.7	4.5	8	8	3.4	30	Φ17H9 ⁰ ₀ ^{+0.043}	Dp:2	16	M3×0.5	4
20	9.5	29	20	52.8	84.8	50	26.3 ^{+2.2} _{0.2}	16.3 ⁰ _{-0.7}	8 ⁰ _{-0.1}	30	M5×0.8	8	10	10	4.3	35	Φ21H9 ⁰ ₀ ^{+0.052}	Dp:3	18.6	M4×0.7	5
25	11	30	25	63.6	102.7	63	33.3 ^{+2.5} _{0.2}	19.3 ⁰ _{-0.8}	10 ⁰ _{-0.1}	36	M6×1	10	12	12	5.1	36.5	Φ26H9 ⁰ ₀ ^{+0.052}	Dp:3.5	22	M5×0.8	6
32	12	40(49)	29	67(76)	113(122)	97	48 ^{+2.5} ₀	26 ⁰ _{-0.5}	12 ⁰ _{-0.1}	46	M6×1	10	13	13	5.1	48(57)	Φ34H9 ⁰ ₀ ^{+0.062}	Dp:4	26	M6×1	7
40	15	49(62)	36	83(96)	139(152)	119	60 ^{+2.7} ₀	30 ⁰ _{-0.5}	14 ⁰ _{-0.1}	56	M8×1.25	13	16	17	6.6	58(71)	Φ42H9 ⁰ ₀ ^{+0.062}	Dp:4	32	M8×1.25	9

Bore(mm)	R	S	T	U	V	W	X	Y	Z	Y1	Y2	AA	BB	CC	DD	EE	
10	5.7	M3×0.5	23	9	19	5 ⁰ _{-0.05}	11	Φ2H9 ⁰ ₀ ^{+0.025}	Dp:3	16.4±0.05	5.2±0.02	7.6±0.02	18	12	-	-	
16	7	M5×0.8	30.6	7.5	19	8 ⁰ _{-0.05}	13	Φ3H9 ⁰ ₀ ^{+0.025}	Dp:3	23.6±0.05	6.5±0.02	11±0.02	22	15	11.6	2.1	5.8
20	9	M5×0.8	42	10	23	10 ⁰ _{-0.05}	15	Φ4H9 ⁰ ₀ ^{+0.03}	Dp:4	27.6±0.05	7.5±0.02	16.8±0.02	32	18	14	2.1	9
25	12	M5×0.8	52	10.7	23.5	12 ⁰ _{-0.05}	20	Φ4H9 ⁰ ₀ ^{+0.03}	Dp:4	33.6±0.05	10±0.02	21.8±0.02	40	22	19	3.5	11.5
32	14	M5×0.8	60	11	31(37)	15 ⁰ _{-0.05}	24	Φ5H9 ⁰ ₀ ^{+0.03}	Dp:5	40±0.1	12±0.02	23±0.02	46	26	24	3.3	11.5
40	17	M5×0.8	72	12	38(45)	18 ⁰ _{-0.05}	28	Φ5H9 ⁰ ₀ ^{+0.03}	Dp:5	48±0.1	14±0.02	29±0.02	56	32	29.4	3.7	13

Overall Dimensions

XHZL-□□ (Φ10~Φ25)
Double acting
Single acting

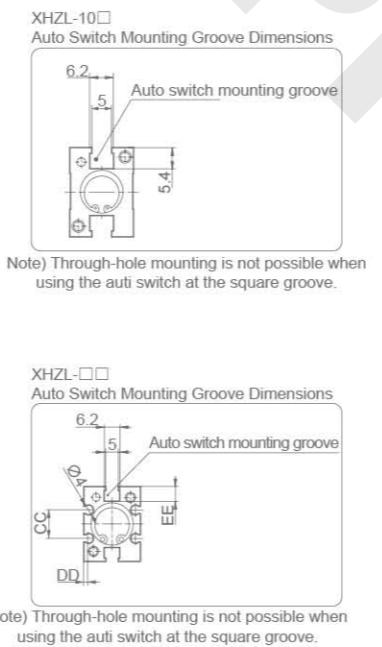
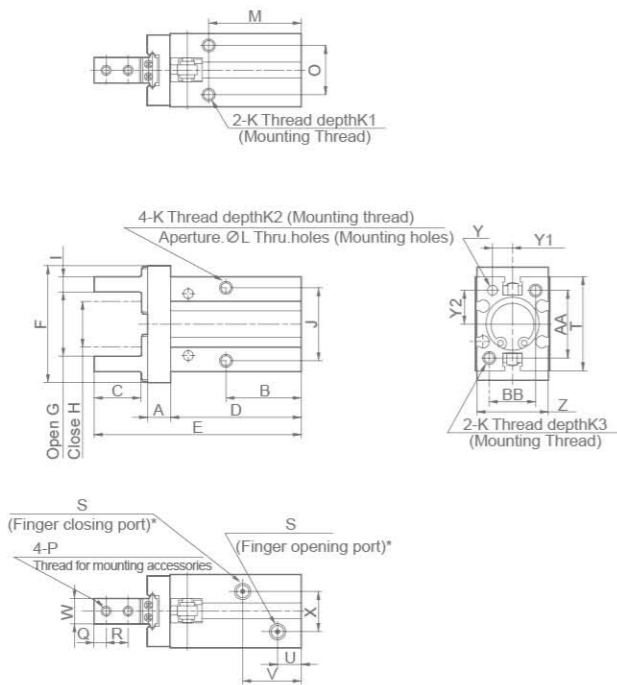

Dimension Sheet

Bore(mm)	A	B	C	D	E	F	G	H	I	J	K	K1	K2	K3	ΦL	M	N	O	P	Q	
10	6	25(35)	12	37.8(47.8)	57(67)	35	19.2 ^{+2.2} ₀	11.2 ⁰ _{-0.7}	4 ⁰ _{-0.1}	16	M3×0.5	6	5.5	6	2.6	29(39)	Φ11H9 ⁰ ₀ ^{+0.043}	Dp:2	11.4	M2.5×0.45	3
16	7.5	31(36)	15	45.2(50.2)	70(75)	47	26.9 ^{+2.2} _{0.2}	14.9 ⁰ _{-0.7}	5 ⁰ _{-0.1}	24	M4×0.7	4.5	8	8	3.4	36(41)	Φ17H9 ⁰ ₀ ^{+0.043}	Dp:2	16	M3×0.5	4
20	9.5	36(42)	20	58(64)	90(96)	62	34.3 ^{+2.2} _{0.2}	16.3 ⁰ _{-0.7}	8 ⁰ _{-0.1}	30	M5×0.8	8	10	10	4.3	43(49)	Φ21H9 ⁰ ₀ ^{+0.052}	Dp:3	18.6	M4×0.7	5
25	11	40(50)	25	66.9(76.9)	106(116)	75	41.3 ^{+2.5} _{0.2}	19.3 ⁰ _{-0.8}	10 ⁰ _{-0.1}	36	M6×1	10	12	12	5.1	48(58)	Φ26H9 ⁰ ₀ ^{+0.052}	Dp:3.5	22	M5×0.8	6

Bore(mm)	R	S	T	U	V	W	X	Y	Z	Y1	Y2	AA	BB	CC	DD	EE	
10	5.7	M3×0.5	23	8	21(31)	5 ⁰ _{-0.05}	11	Φ2H9 ⁰ ₀ ^{+0.025}	Dp:3	16.4±0.05	5.2±0.02	7.6±0.02	18	12	-	-	
16	7	M5×0.8	30.6	8	25(30)	8 ⁰ _{-0.05}	13	Φ3H9 ⁰ ₀ ^{+0.025}	Dp:3	23.6±0.05	6.5±0.02	11±0.02	22	15	11.6	2.1	5.8
20	9	M5×0.8	42	10	30(36)	10 ⁰ _{-0.05}	15	Φ4H9 ⁰ ₀ ^{+0.03}	Dp:4	27.6±0.05	7.5±0.02	16.8±0.02	32	18	14	2.1	9
25	12	M5×0.8	52	10	33(43)	12 ⁰ _{-0.05}	20	Φ4H9 ⁰ ₀ ^{+0.03}	Dp:4	33.6±0.05	10±0.02	21.8±0.02	40	22	19	3.5	11.5

XHY Series Style Air Gripper



XHY2-25D

Ordering Code

XHY - 2 - 16 - D - 2

Series Code
XHY:180° open and close your fingers

Finger Quantity
2PCS

Bore size
10mm~25mm

Action Type
D:Double Action

Claw form
Blank:Standard thread installation
2:Opening and closing direction through-hole installation



- Auto switch is attachable.
- 180°Retractable simplify pick and place operation.
- May be suitable for use under special circumstances,the finger opening and closing part specifically designed to prevent small items from entering.
- Easy to install, with positioning holes.

Specification

Bore(mm)	10	16	20	25
Working Medium	Air(to be filtered by 40µm filter element)			
Action Type	Double-acting			
Max.operating Pressure(Mpa)	0.6			
Min.operating Pressure(Mpa)	0.1			
Ambient Fluid Temperature	-10~+60°C			
Max.operating Frequency	60c.p.m			
Repeatability(Mm)	±0.2mm			
Holding Torque N·m Note1)	0.16	0.54	1.10	2.28
Lubrication Note2)	Not required			
Port Size	M5×0.8			

Note 1) At the pressure of 0.5 Mpa
Note 2)If you need lubrication,use turbine No.1 oil ISO VG32.

Chart

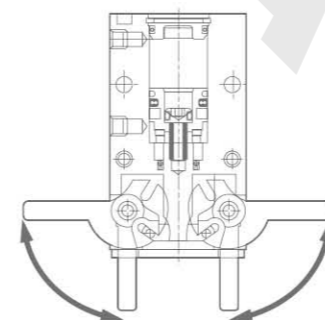

Function Example

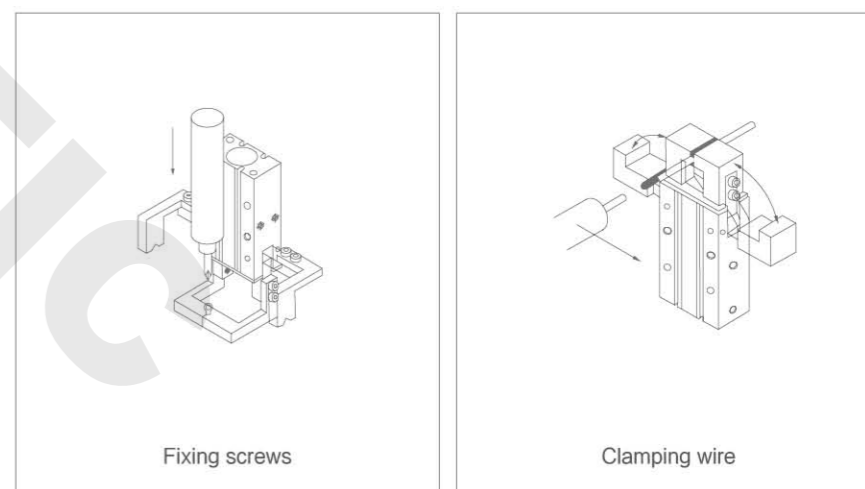

XHY Series Style Air Gripper

Overall Dimensions

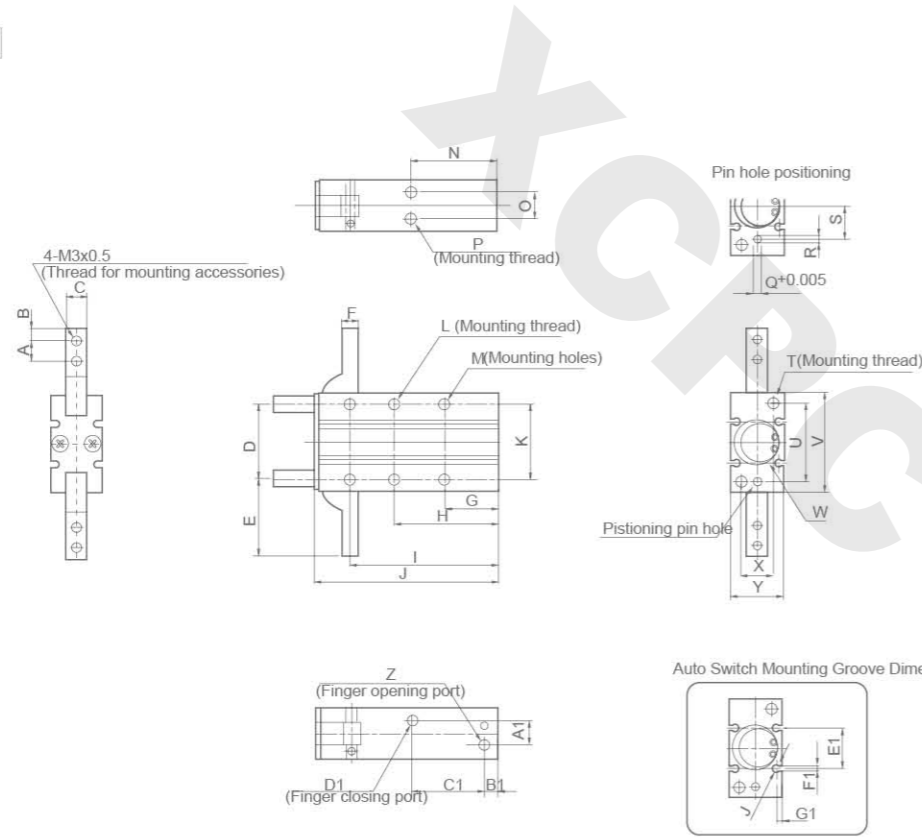

Dimension Sheet

Bore(mm)	A	B	C	D	E	F	G	H
10	6	3	6 ^{-0.05/-0.025}	22	23.5	4	18	35
16	7	4	8 ^{-0.05/-0.025}	28	28.5	10	20	41
20	9	5	10 ^{-0.05/-0.025}	36	37	8	25	50
25	12	6	12 ^{-0.05/-0.025}	45	45	10	30	60

Bore(mm)	I	J	K	L	M	N	O	P
10	47.5	58	24	4-M3x0.5/Thread dep 6	2-Φ3.4	30	19	2-M3x0.5/Thread dep 6
16	55.5	69	30	4-M3x0.7/Thread dep 8	2-Φ4.5	33	12	2-M4x0.7/Thread dep 5
20	69	86	36	4-M5x0.8/Thread dep 10	2-Φ5.5	42	14	2-M5x0.8/Thread dep 10
25	86	107	30	4-M6x1/Thread dep 12	2-Φ6.6	52	12	2-M6x1/Thread dep 10

Bore(mm)	Q	R	S	T	U	V	W	X
10	3H9 ^{+0.05/0}	4	9	2-M3x0.5/Thread dep 6	24	30	Φ11h9 ^{+0.043/0}	9
16	3H9 ^{+0.025/0}	4	19	2-M3x0.7/Thread dep 8	30	38	Φ17h9 ^{+0.043/0}	12
20	4h9 ^{+0.030/0}	5	19	2-M5x0.8/Thread dep 10	38	48	Φ21h9 ^{+0.052/0}	16
25	4h9 ^{+0.052/0}	5	23	2-M6x1/Thread dep 12	46	58	Φ26h9 ^{+0.052/0}	18

Bore(mm)	Y	Z	A1	B1	C1	D1	E1	F1	G1
10	15	M5x0.8	3	7	23	M5x0.8	13	3	2
16	20	M5x0.8	8	7	25	M5x0.8	18	3	2.5
20	26	M5x0.8	12	8	32	M5x0.8	20	3	3
25	30	M5x0.8	14	8	42	M5x0.8	24	3	3

XHC Series Style Air Gripper



XHC2-25D

Graphic Symbol

Double Action

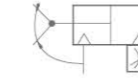

Single Action

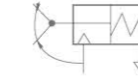

Ordering Code

XHC	2	16	D
Series Code	Finger Quantity	Bore Size	Action Type
XHC:fulcrum opening and closing fingers	2PCS	10mm~25mm	D:Double Action S:Single Action

Specification

Bore(mm)	10	16	20	25
Working Medium	Air(to be filtered by 40μm filter element)			
Operating pressure MPa	Double-acting	0.25~0.6MPa		
	Single acting	0.1~0.6MPa		
Ambient fluid temperature	-10~60°C			
The highest frequency of use(c.p.m)	180c.p.m			
Repeatability Precision(mm)	±0.01			
Lubrication	Not required			
Port Size	M3x0.5	M5x0.8		

Holding torque

Action	Model	Bore size	Gripping momeng	Opening/Closing angle (Both sides)
Double-acting	XHC	-10D	0.1	30°~10°
		-16D	0.39	
		-20D	0.70	
		-25D	1.36	
Single acting	XHC	-10S	0.07	30°~10°
		-16S	0.31	
		-20D	0.54	
		-25D	1.08	

Overall Dimensions

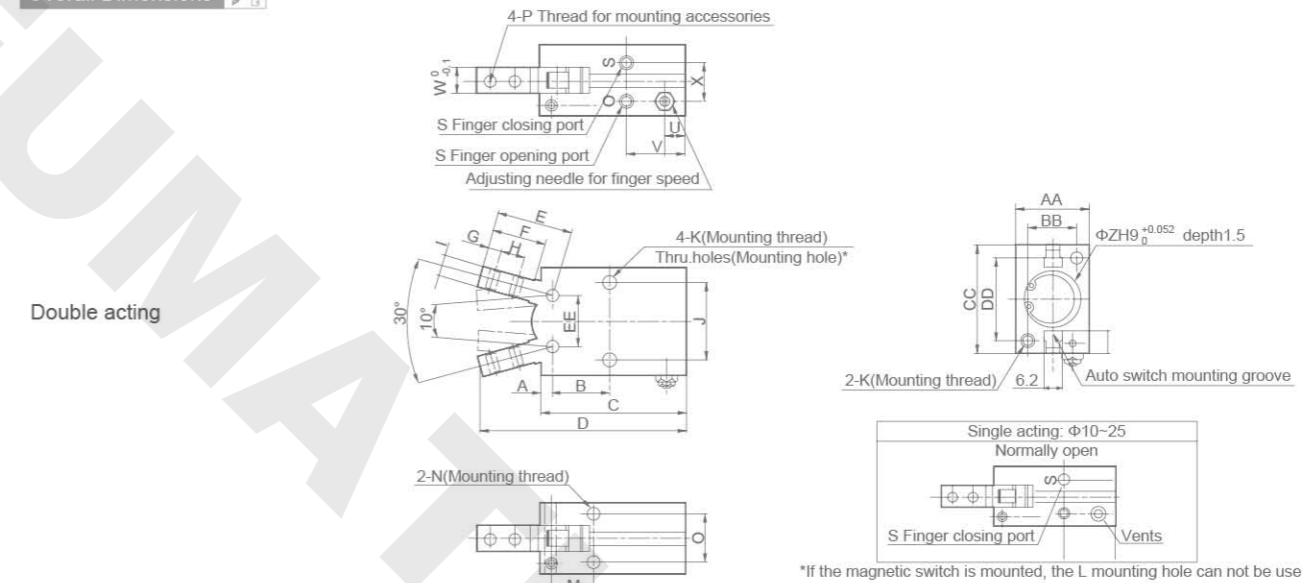

Dimension Sheet

Bore (mm)	A	B	C	D	E	F	G	H	I	J	K	L	M	N	O	P	Port size		U	V	W	X	Y	Z	AA	BB	CC	DD	EE	
	S		T																											
10	2.8	12.8	38.6	52.4	17.2	12	3	5.7	4	16	M3x0.5	Dp.5	2.6	8.8	M3x0.5	Dp.6	11.4	M25x0.45	M3x0.25	7.2	18.8	6.4	10.4	5.4	11	16.4	12	23	18	10
16	3.9	16.2	44.6	62.5	22.6	16	4	7	7	24	M4x0.7	Dp.8	3.4	10.7	M4x0.7	Dp.8	16	M3x0.5	M5x0.8	7	18.3	8	13	5.8	17	23.6	15	30.6	22	16
20	4.5	21.7	55.2	78.7	28	20	5.2	9	8	30	M5x0.8	Dp.10	4.3	15.7	M5x0.7	Dp.8	18.6	M4x0.7	M5x0.8	7.5	22.2	10	15	9	21	27.6	18	42	32	20
25	4.6	25.8	60.2	92	37.5	27	8	12	10	36	M6	Dp.12	5.1	19.3	M6	Dp.10	22	M5	M5x0.8	7.7	23.5	12	20	11.5	26	33.6	22	52	40	25