

### MAL Series Aluminum alloy Mini Cylinder



MAL 25 x 50

MALJ 25 x 50-25

Ordering Code

**MAL** - □ 20 × 50 - 25 - S - □

**Series Code**  
 MAL: Double Action type  
 MSAL: Single Extrusion Type  
 MTAL: Single Drwing-in Type  
 MALD: Double-shaft Double Action Type  
 MALCD: Double-shaft Action Damping Type  
 MALJ: Double-shaft And Adjustable Stroke Type  
 MALC: With Cushion Type

**Back Cover Type**  
 Blank: Fishtail type  
 CM: Rounded type  
 U: Horizontal type

**Cylinder Bore**  
 16mm-40mm

**Stroke**  
 25

**Adjustable Stroke Type**  
 0~100mm

**Magnet Code**  
 Blank: Without Magnet  
 S: With Magnet

**Fixed Type**  
 Blank: Normal type  
 LB: Front and back fixed type  
 FA: Front cover fixed type  
 SDB: Back cover swinging type

Internal structure

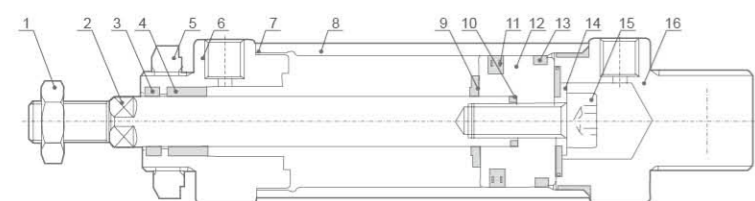

NO	Designation	NO	Designation
1	Piston Rod Nut	2	Piston Rod
3	Front Cover Seal Ring	4	Oiled Bearing
5	Front Cover Nut	6	Front Cover
7	Pipe wall O-ring	8	Aluminum tube
9	Anti-crash cushion	10	Piston rod O-Ring
11	Piston O-Ring	12	Piston
13	Wear ring	14	Back cushion
15	Hex socket screw	16	Back Cover

Specifcation

Bore(mm)	16	20	25	32	40
Motion Pattern	Double Action or Single Action				
Working Medium	Air				
Fixed Type	Normal Type LB Type FA Type SDB Type				
Operating Pressure Range	0.1~0.9MPa				
Ensured Pressure Resistance	1.35MPa				
Operating Temperature Range	-5~70℃				
Operating Speed Range	30~800mm/s				
Buffer Type	Standard Type Anti-crash cushion Damping Type Adjustable cushion				
Port Size	M5×0.8	G1/8"	G1/8"	G1/8"	G1/4"

Our Company can also make flat for cylinder covers inlet and outlet position. If you require this, it should be specified.

### MAL Series Aluminum alloy Mini Cylinder

Stroke

Bore(mm)	Standard Stroke										Max. Stroke(mm)	Max. Stroke(mm)					
16	25	50	75	80	100	125	160	175	200		300	500					
20	25	50	75	80	100	125	160	175	200	250	300	500	650				
25	25	50	75	80	100	125	160	175	200	250	300	350	400	450	500	500	650
32	25	50	75	80	100	125	160	175	200	250	300	350	400	450	500	500	650
40	25	50	75	80	100	125	160	175	200	250	300	350	400	450	500	500	650

Overall Dimensions

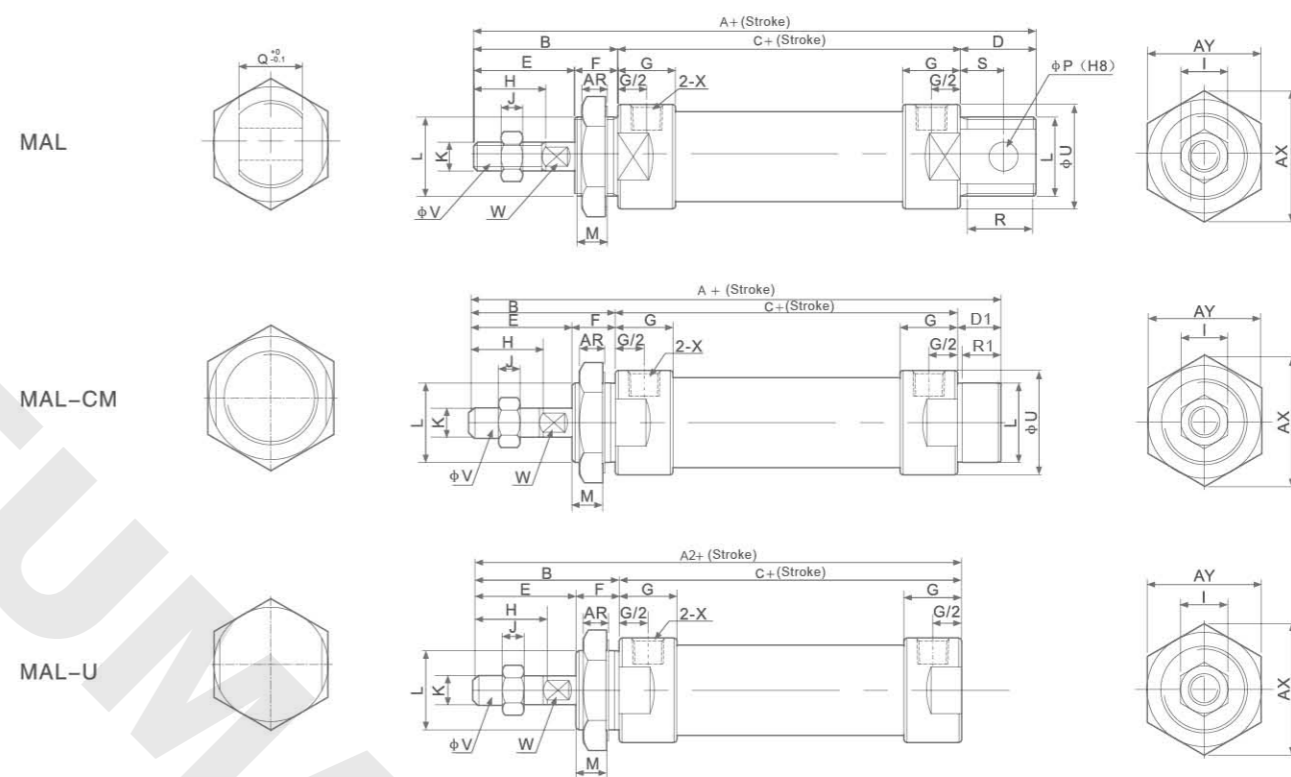

Dimension Sheet

Bore/Symbol	A	A1	A2	B	C	D	D1	E	F	G	H	I	J	K
16	110	114	98	38	56	16	16	22	16	10	16	10	5	M6×1
20	131	122	110	40	70	21	12	28	12	16	20	12	6	M8×1.25
25	135	128	114	44	70	21	14	30	14	16	22	17	6	M10×1.25
32	141	128	114	44	70	27	14	30	14	16	22	17	6	M10×1.25
40	165	152	138	46	92	27	14	32	14	22	24	17	7	M12×1.25

Bore/Symbol	L	M	P	Q	R	R1	S	U	V	W	X	AR	AX	AY
16	M16×1.5	14	6	12	14	14	9	24	6	5	M5	6	25	22
20	M22×1.5	10	8	16	19	10	12	29	8	6	G1/8"	7	33	29
25	M22×1.5	12	8	16	19	12	12	34	10	8	G1/8"	7	33	29
32	M24×2.0	12	10	16	25	12	15	39.5	12	10	G1/8"	8	37	32
40	M30×2.0	12	12	20	25	12	15	49.5	16	14	G1/4"	9	37	41

### MAL Series Aluminum alloy Mini Cylinder

Overall Dimensions



Dimension Sheet

Symbol Bore/Stroke	A		A1		A2		B	C		D	D1	E	F	G	H	I	J
	0-50	51-100	0-50	51-100	0-50	51-100		0-50	51-100								
20	131	156	122	147	110	135	40	70	95	21	12	28	12	16	20	12	6
25	135	160	160	153	114	139	44	70	95	21	14	30	14	16	22	17	6
32	141	166	166	153	114	139	44	70	95	27	14	30	14	16	22	17	6
40	165	190	190	177	138	163	46	92	117	27	14	32	14	22	24	17	7

Bore/Symbol	K	L	M	P	Q	R	R1	S	U	V	W	X	AR	AX	AY
20	M8×1.25	M22×1.5	10	8	16	19	10	12	29	8	6	G1/8"	7	33	29
25	M10×1.25	M22×1.5	12	8	16	19	12	12	34	10	8	G1/8"	7	33	29
32	M10×1.25	M24×2.0	12	10	16	25	12	15	39.5	12	10	G1/8"	8	37	32
40	M12×1.25	M30×2.0	12	12	20	25	12	15	49.5	16	14	G1/8"	9	47	41

Overall Dimensions

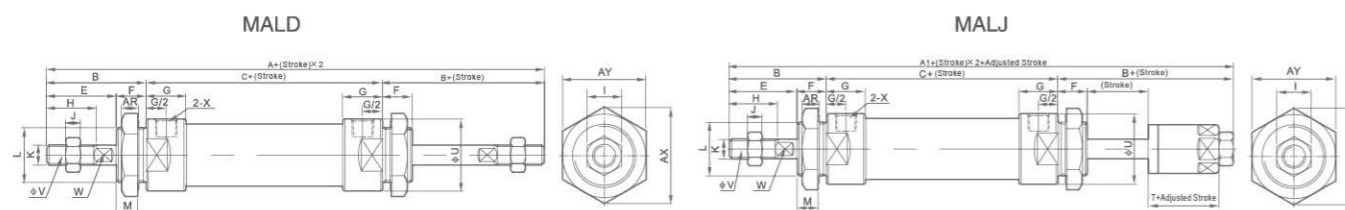

Dimension Sheet

Bore/Symbol	A	A1	B	C	E	F	G	H	I	L	K
20	150	147	40	70	28	12	16	20	12	6	M8×1.25
25	158	155	44	70	30	14	16	22	17	6	M10×1.25
32	158	155	44	70	30	14	16	22	17	6	M10×1.25
40	184	180	46	92	32	14	22	24	17	7	M12×1.25

Bore/Symbol	L	M	U	V	W	X	AR	AX	AY	T
20	M22×1.5	10	29	8	6	G1/8"	7	33	29	19
25	M22×1.5	12	34	10	8	G1/8"	7	33	29	21
32	M24×1.5	12	39.5	12	10	G1/8"	8	37	32	21
40	M30×2.0	12	49.5	16	14	G1/4"	9	47	41	21

### CM2 Series Stainless Steel Mini Cylinder

Ordering Code

**CM2** × **32** × **150** - **A**  
**Series Code** CM2B:Normal Type  
**Cylinder Bore** 20mm-40mm  
**Stroke** 0~1000mm  
**Buffer** Blank:Rubber Buffer  
 A:Air Buffer



CDM2B 32 × 50

CDM2B 20 × 50

Internal structure

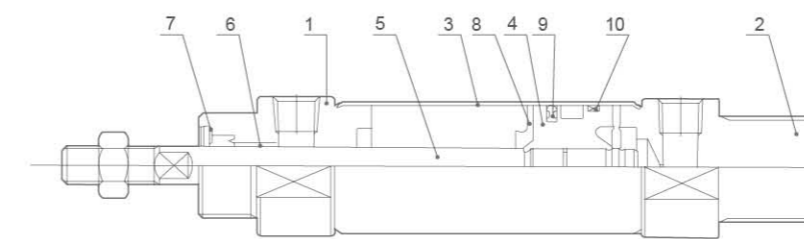

NO	Designation
1	Front Cover
2	Back Cover
3	Barrel
4	Piston
5	Piston rod
6	Oiled Bearing
7	Front Cover Seal Ring
8	Anti-crash cushion
9	Piston Seal
10	Wear Ring

Specification

Bore(mm)	20	25	32	40
Working Medium	Air			
Motion Pattern	Double action			
Ensured Pressure Resistance	15.3kgf/cm <sup>2</sup> (1.5Mpa)			
Max.pressure	10.2kgf/cm <sup>2</sup> (1.0Mpa)			
Min.pressure	0.5kgf/cm <sup>2</sup> (0.05Mpa)			
Operating Temperature Range	-10~+70℃			
Operating Speed Range	50~750mm/s			
Buffering	Rubber buffer(Standard),Air buffer(Optional)			
Margin of Stroke Error(mm)	+1.4 0mm			
Port size	G1/8"	G1/8"	G1/8"	G1/4"

Overall Dimensions

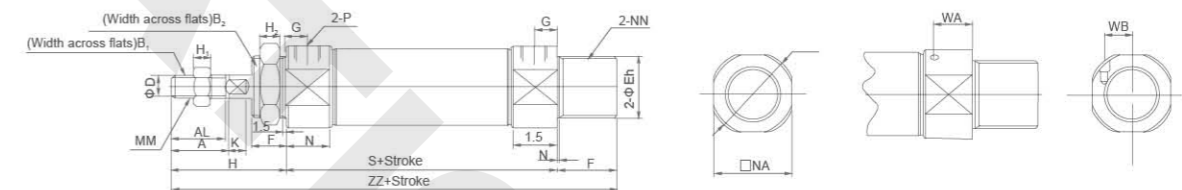

Dimension Sheet

Bore	Stroke range	A	AL	B1	B2	D	E	F	G	H	H1	H2	I	K	MM	N	NA	NN	P	S	ZZ	WA	WB
20	~300	18	15.5	13	26	8	20 <sup>0</sup> <sub>-0.033</sub>	13	8	41	5	8	28	5	M8×1.25	15	24	M20×1.5	1/8	62	116	11.5	8.5
25	~300	22	19.5	17	32	10	20 <sup>0</sup> <sub>-0.033</sub>	13	8	45	6	8	22.5	5.5	M10×1.25	15	30	M26×1.5	1/8	62	120	11.5	10
32	~300	22	19.5	17	32	12	26 <sup>0</sup> <sub>-0.033</sub>	13	8	45	6	8	37.5	5.5	M10×1.25	15	34.5	M26×1.5	1/8	64	122	11.5	11.5
40	~300	24	21	22	41	14	32 <sup>0</sup> <sub>-0.033</sub>	16	11	50	6	10	46.5	7	M14×1.5	21.5	42.5	M32×1.5	1/4	88	154	14	15