

Assembly Kits for Pneumatic Cylinder

DNC Series Cylinder Kits

Product	Model/ Specification	Part name	Material	Part name	Material
 <p>DNC Kits (ISO15552) Bore size: Φ32,40, 50,63,80, 100,125</p>		Front cover	Aluminum alloy	Piston seal	NBR
		Back cover	Aluminum alloy	Wear ring	PA66
		Piston	Aluminum alloy	Self lubricating bearing	PTFE+Brass
		Piston rod(Without)	S45C hard chrome carbon steel	Magnet(optional)	RbFeb
		Barrel(Without)	Hard anodized aluminum	Cushion needle	Brass
		Front Cover seal	PU	Hexagon screw	Carbon steel
		Cushion seal	NBR	Nut	Carbon steel
		Piston rod O-ring	NBR	Profile bolt	Carbon steel
		Cover O-ring	NBR		

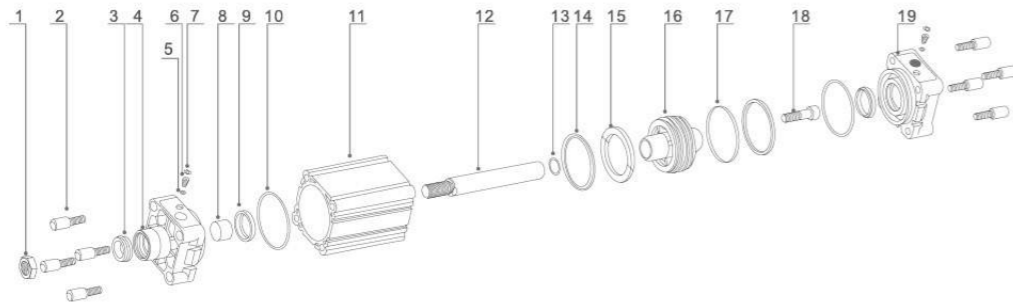

NO	Designation	NO	Designation	NO	Designation	NO	Designation	NO	Designation
1	Nut	5	O-ring	9	Cushion seal	13	Rod O-ring	17	Wear ring
2	Profile bolt	6	Adjustable screw	10	Cover O-ring	14	Piston seal	18	Hex Socket Screw
3	Front Cover seal	7	Block slip	11	Barrel(Without)	15	Magnet(optional)	19	Back cover
4	Front cover	8	Self Lubricating bearing	12	Piston rod(Without)	16	Piston		

DNG Series Cylinder Kits

Product	Model/ Specification	Part name	Material	Part name	Material
 <p>DNG Kits (ISO15552) Bore size: Φ160,200, 250,320</p>		Front cover	Aluminum alloy	Piston seal	NBR
		Back cover	Aluminum alloy	Wear ring	PA66
		Piston	Aluminum alloy	Self lubricating bearing	PTFE+Brass
		Piston rod(Without)	S45C hard chrome carbon steel	Magnet(optional)	RbFeb
		Barrel(Without)	Hard anodized aluminum	Cushion needle	Brass
		Front Cover seal	PU	Hexagon screw	Carbon steel
		Cushion seal	NBR	Nut	Carbon steel
		Piston rod O-ring	NBR	Profile bolt	Carbon steel
		Cover O-ring	NBR		

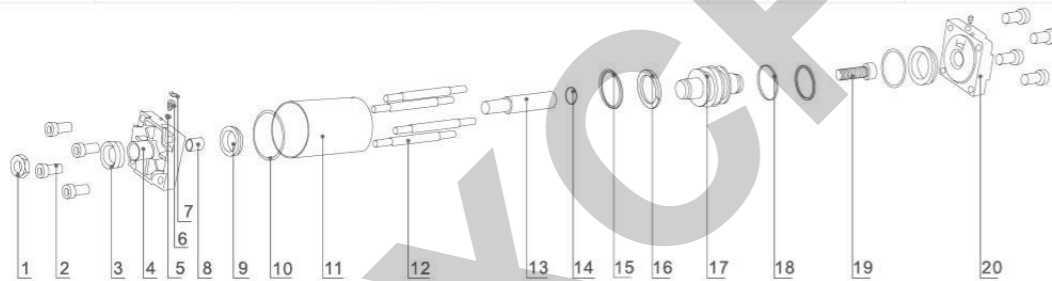

NO	Designation	NO	Designation	NO	Designation	NO	Designation	NO	Designation
1	Nut	5	O-ring	9	Cushion seal	13	Tierod(Without)	17	Piston
2	Profile bolt	6	Adjustable screw	10	Cover O-ring	14	Rod O-ring	18	Wear ring
3	Front Cover seal	7	Block slip	11	Barrel(Without)	15	Piston seal	19	Hex Socket Screw
4	Front cover	8	Self Lubricating bearing	12	Piston rod(Without)	16	Magnet(optional)	20	Back cover

Assembly Kits for Pneumatic Cylinder

SI Series Cylinder Kits

Product	Model/ Specification	Part name	Material	Part name	Material
 <p>SI Kits (ISO6431) Bore size: Φ32,40,50, 63,80,100,125, 160,200</p>		Front cover	Aluminum alloy	Piston seal	NBR
		Back cover	Aluminum alloy	Wear ring	PA66
		Piston	Aluminum alloy	Self lubricating bearing	PTFE+Brass
		Piston rod(Without)	S45C hard chrome carbon steel	Magnet(optional)	RbFeb
		Barrel(Without)	Hard anodized aluminum	Cushion needle	Brass
		Front Cover seal	NBR	Hexagon screw	Carbon steel
		Cushion seal	NBR	Nut	Carbon steel
		Piston rod O-ring	NBR	Profile bolt	Carbon steel
		Cover O-ring	NBR		

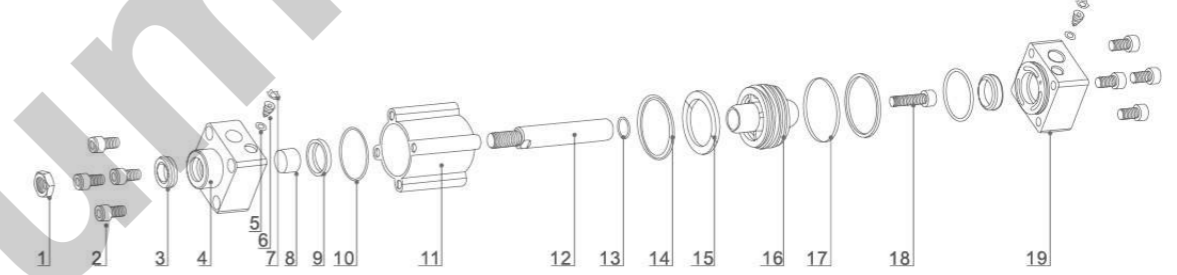

NO	Designation	NO	Designation	NO	Designation	NO	Designation	NO	Designation
1	Nut	5	O-ring	9	Cushion seal	13	Rod O-ring	17	Wear ring
2	Profile bolt	6	Adjustable screw	10	Cover O-ring	14	Piston seal	18	Hex Socket Screw
3	Front Cover seal	7	Block slip	11	Barrel(Without)	15	Magnet(optional)	19	Back cover
4	Front cover	8	Self Lubricating bearing	12	Piston rod(Without)	16	Piston		

SC Series Cylinder Kits

Product	Model/ Specification	Part name	Material	Part name	Material
 <p>SC Kits Bore size: Φ32,40,50, 63,80,100,125, 160,200.</p>		Front cover	Aluminum alloy	Piston seal	NBR
		Back cover	Aluminum alloy	Wear ring	PA66
		Piston	Aluminum alloy	Self lubricating bearing	PTFE+Brass
		Piston rod(Without)	S45C hard chrome carbon steel	Magnet(optional)	RbFeb
		Barrel(Without)	Hard anodized aluminum	Cushion needle	Brass
		Front Cover seal	NBR	Hexagon screw	Carbon steel
		Cushion seal	NBR	Nut	Carbon steel
		Piston rod O-ring	NBR	Tie-rod nut	Carbon steel
		Cover O-ring	NBR		

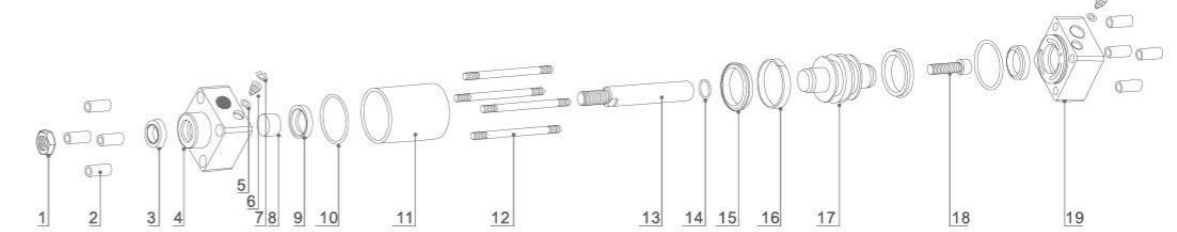

NO	Designation	NO	Designation	NO	Designation	NO	Designation	NO	Designation
1	Nut	5	O-ring	9	Cushion seal	13	Piston rod(Without)	17	Piston
2	Tie-rod nut	6	Adjustable screw	10	Cover O-ring	14	Rod O-ring	18	Hex Socket Screw
3	Front Cover seal	7	Block slip	11	Barrel(Without)	15	Piston seal	19	Back cover
4	Front cover	8	Self Lubricating bearing	12	Tie rod(Without)	16	Wear ring		