

### MGP Series Three-Shaft Cylinder



MGPM 20 x 30



MGPM 25 x 50

Ordering Code

**MGP**      **M**      **25**      ×      **40**

**Series Code**  
MGP: Attach magnet Type

**Type of Bearing**  
M: Slide Bearing  
L: Ball Guide Bearing

**Cylinder Bore**  
12mm-100mm

**Stroke**  
10~200mm  
Note: Non-standard stroke like (5,10,15,20,35.....) we are add subplate of 5,10,15, 20mm on standard stroke.

Specification

Bore(mm)	12	16	20	25	32	40	50	63	80	100
Working Medium	Air									
Motion Pattern	Double-action									
Ensured Pressure Resistance	1.5Mpa(15.3kgf/cm <sup>2</sup> )									
Max. Operating pressure	1.0Mpa(10.2kgf/cm <sup>2</sup> )									
Min. Operating pressure	0.12Mpa(1.2kgf/cm <sup>2</sup> )									
Ambient and Medium Temperature	-10~+60°C									
Piston Speed	50~500mm/s					50~400mm/s				
Buffer	Rubber Cushion									
Tolerance of Stroke	+1.5 0 mm									
Bearing	Slide bearing/ball guide bearing									
Precision of Piston rod Non-rotating	Slide Bearing	±0.08°	±0.07°	±0.06°	±0.05°	±0.04°				
	Ball Guide Bearing	±0.10°	±0.09°	±0.08°	±0.06°	±0.05°				
Port size	M5×0.8		G1/8"			G1/4"		G3/8"		

Standard Stroke

Bore size (mm)	Standard stroke (mm)
12,16	10,20,30,40,50,75,100,125,150,175,200,250
20,25	20,30,40,50,75,100,125,150,175,200,250,300,350,400
32 to 100	25,50,75,100,125,150,175,200,250,300,350,400

Note: MGP Series cylinder with 100mm Bore is Being Developed. Not Available At the moment.

### MGP Series Three-Shaft Cylinder

Overall Dimensions

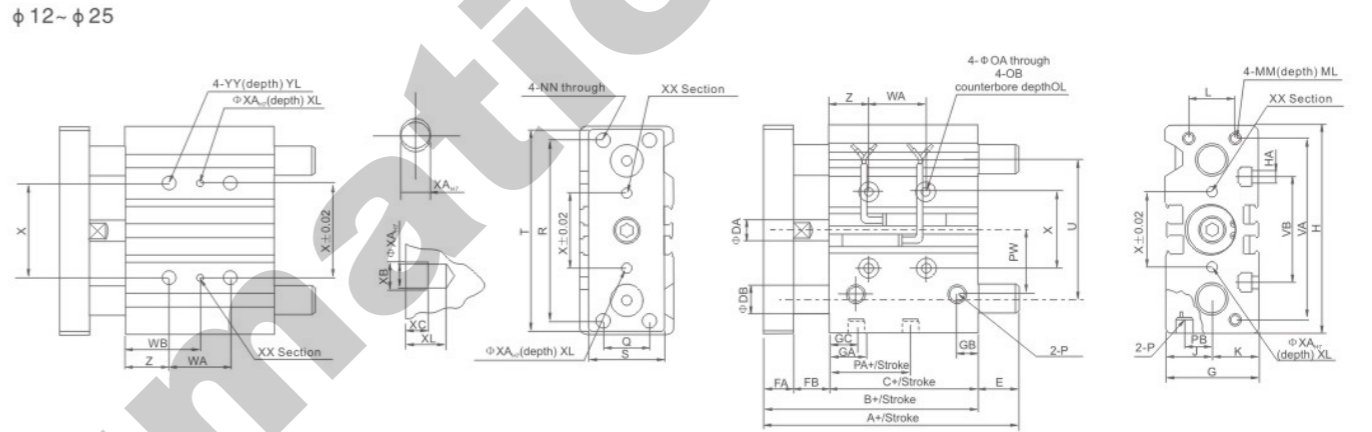

MGPM, MGPL Common Dimensions Sheet

Bore size	Standard stroke (mm)	B	C	DA	FA	FB	G	GA	GB	H	HA	J	K	L	MM	ML	NN	OA
12	10,20,30,40, 50,75,100	42	29	6	8	5	26	11	7.5	58	M4	13	13	18	M4×0.7	10	M4×0.7	4.3
16	20,30,40,50, 75,100,125,150,175,200	46	33	8	8	5	30	11	8	64	M4	15	15	22	M5×0.8	12	M5×0.8	4.3
20	20,30,40,50, 75, 100,125,150,175,200	53	37	10	10	6	36	10.5	8.5	83	M5	18	18	24	M5×0.8	13	M5×0.8	5.6
25	20,30,40,50, 75, 100,125,150,175,200	53.5	37.5	12	10	6	42	11.5	9	93	M5	21	21	30	M6×1.0	15	M6×1.0	5.6

Bore size	Standard stroke (mm)	OB	OL	P	PA	PB	PW	Q	R	S	T	U	VA	VB	X	XA	XB	XC	YL	Z
12	10,20,30,40, 50,75,100	8	4.5	M5×0.8	13	8	18	14	48	22	56	41	50	37	23	3	3.5	3	10	5
16	20,30,40,50, 75,100,125,150,175,200	8	4.5	M5×0.8	15	10	19	16	54	25	62	46	56	38	24	3	3.5	3	10	5
20	20,30,40,50, 75, 100,125,150,175,200	9.5	5.5	RC1/8	12.5	10.5	25	18	70	30	81	54	72	44	28	3	3.5	3	12	17
25	20,30,40,50, 75, 100,125,150,175,200	9.5	5.5	RC1/8	12.5	13.5	28.5	26	78	38	91	64	82	50	34	4	4.5	3	12	17

Bore size	Standard stroke (mm)	WA			WB			XL	YY
		30 st or less	Over 40 st to 100 st	125 st or less	30 st or less	Over 40 st to 100 st	125 st or less		
12	10,20,30,40, 50,75,100	20	40	-	15	25	-	6	M5×0.8
16	20,30,40,50, 75,100,125,150,175,200	24	44	-	17	27	-	6	M5×0.8
20	20,30,40,50, 75, 100,125,150,175,200	24	44	120	29	39	77	6	M6×1.0
25	20,30,40,50, 75, 100,125,150,175,200	24	44	120	29	39	77	6	M6×1.0

MGPG Slide bearing

Bore size	A				DB	E		
	50st≥	50st< 100st≥	100st<	50st≥		50st< 100st≥	100st<	
12	42	60.5	85	8	0	18.5	43	
16	46	64.5	95	10	0	18.5	49	

MGPL Ball bushing bearing

Bore size	A				DB	E		
	30st≥	30st< 100st≥	100st<	30st≥		30st< 100st≥	100st<	
12	43	55	85	6	1	13	43	
16	49	65	95	8	3	19	49	

MGPM Slide bearing

Bore size	A			DB	E		
	50st≥	50st< 200st≥	200st<		50st≥	50st< 200st≥	200st<
20	53	84.5	122	16	0	31.5	69
25	53.5	85	122	20	0	31.5	68.5

MGPL Ball bushing bearing

Bore size	A				DB	E			
	30st≥	30st< 100st≥	100st< 200st≥	200st<		30st≥	30st< 100st≥	100st< 200st≥	200st<
20	63	80	104	122	10	10	27	51	69
25	69.5	80.5	104.5	122	13	16	32	51	68.5

### MGP Series Three-Shaft Cylinder

Overall Dimensions

φ 32~φ 63

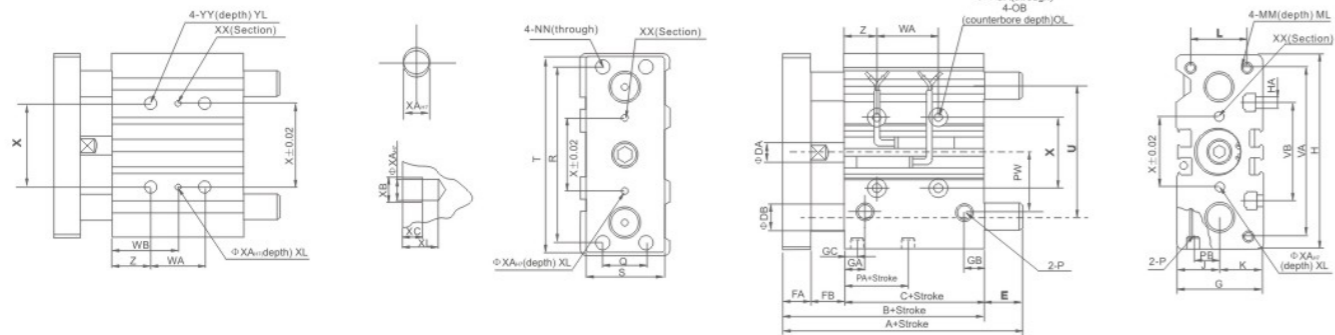

MGPM, MGPL Common Dimensions Sheet

Bore size	Standard stroke(mm)	B	C	DA	FA	FB	G	GA	GB	GC	H	HA	J	K	L	MM	ML	NN	OA
32	25,50,70,100, 125,150,175,200	59.5	37.5	16	12	10	48	12.5	9	12.5	112	M6	24	24	34	M8×1.25	20	M8×1.25	6.6
40		66	44	16	12	10	54	14	10	14	120	M6	27	27	40	M8×1.25	20	M8×1.25	6.6
50		72	44	20	16	12	64	14	11	12	148	M8	32	32	46	M10×1.5	22	M10×1.5	8.6
63		77	49	20	16	12	78	16.5	13.5	16.5	162	M10	39	39	58	M10×1.5	22	M10×1.5	8.6

Bore size	Standard stroke(mm)	OB	OL	P	PA	PB	PW	Q	R	S	T	U	VA	VB	X	XA	XB	XC	XL	Z
32	25,50,70,100, 125,150,175,200	11	7.5	RC1/8	7	15	34	30	96	44	110	78	98	63	42	4	4.5	3	6	21
40		11	7.5	RC1/8	13	18	38	30	104	44	118	86	106	72	50	4	4.5	3	6	22
50		14	9	RC1/4	9	21.5	47	40	130	60	146	110	130	92	66	5	6	4	8	24
63		14	9	RC1/4	14	28	55	50	130	70	158	124	142	110	80	5	6	4	8	24

Bore size	Standard stroke(mm)	WA			WB			YY	YL
		25 st	50,75,100 st	100 st or above	25 st	50,75,100 st	100 st or above		
32	25,50,70, 100,125, 150,175,200	24	48	124	33	45	83	M8×1.25	16
40		24	48	124	34	46	84	M8×1.25	16
50		24	48	124	36	48	86	M10×1.5	20
63		28	52	128	38	50	88	M10×1.5	20

MGPM Slide bearing

Bore size	A			DB	E		
	50st≥	50st<200st≥	200st<		50st≥	50st<200st≥	200st<
32	97	102	140	20	37.5	42.5	80.5
40	97	102	140	20	31	36	74
50	106.5	118	161	25	34.5	46	89
63	106.5	118	161	25	29.5	41	84

MGPL Ball bushing bearing

Bore size	A				DB	E			
	50st≥	50st<100st≥	100st<200st≥	200st<		50st≥	50st<100st≥	100st<200st≥	200st<
32	81	98	118	140	16	21.5	38.5	58.5	80
40	81	98	118	140	16	15	32	52	74
50	93	114	134	161	20	21	42	62	89
63	93	114	134	161	20	16	37	57	84

### MGP Series Three-Shaft Cylinder

Overall Dimensions

φ 80~φ 100

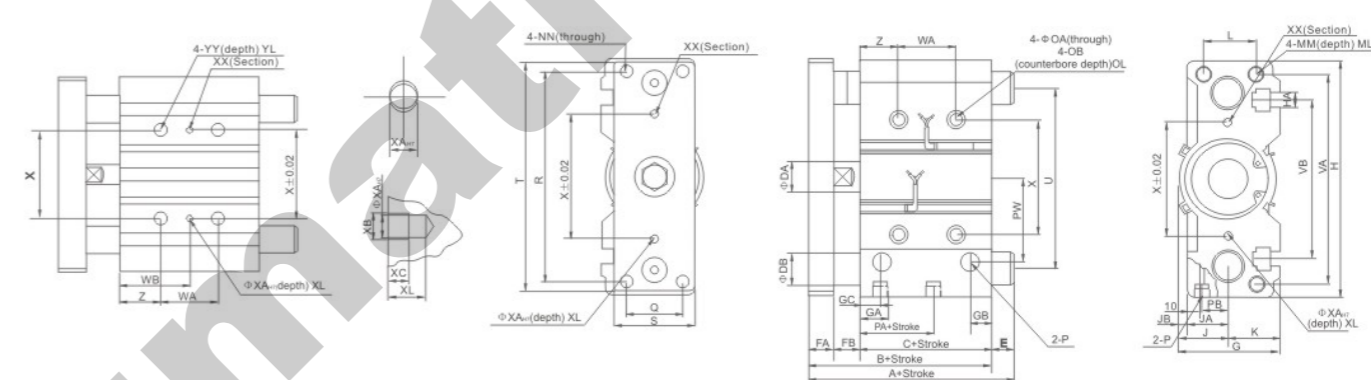

Dimension Sheet

Bore size	Standard stroke (mm)	B	C	DA	FA	FB	G	GA	GB	GC	H	HA	J	LA	JB	K	L	MM	ML	NN	OA
80	20,50,75, 100,125, 150,175,200	95.5	56.5	25	22	18	91.5	19	15.5	14.5	202	M12	45.5	38	7.5	46	54	M12×1.75	30	M12×1.75	10.6
100	150,175,200	116	66	30	25	25	111.5	23	19	18	240	M14	55.5	45	10.5	56	62	M14×2.0	32	M14×2.0	12.5

Bore size	Standard stroke (mm)	OB	OL	P	PA	PB	PW	Q	R	S	T	U	VA	VB	X	XA	XB	XC	XL	Z
		80	20,50,75, 100,125, 150,175,200	17.5	8	RC3/8	14.5	25.5	74	52	174	75	198	156	180	140	100	6	7	5
100	150,175,200	20	8	RC3/8	17.5	32.5	89	64	210	90	236	188	210	166	124	6	7	5	10	11

Bore size	Standard stroke (mm)	WA			WB			YY	YL
		25 st	50,75,100 st	100 st or above	25 st	50,75,100 st	100 st or above		
80	20,50,75, 100,125, 150,175,200	28	52	128	42	54	92	M12×1.75	24
100	150,175,200	48	72	148	35	47	85	M14×2.0	28

MGPM Slide bearing

Bore size	A			DB	E		
	50st≥	50st<200st≥	200st<		50st≥	50st<200st≥	200st<
80	115	142	193	30	18.5	45.5	96.5
100	137	162	203	36	21	46	87

MGPL Ball bushing bearing

Bore size	A				DB	E			
	50st≥	25st<50st≥	50st<200st≥	200st<		50st≥	25st<50st≥	50st<200st≥	200st<
80	109.5	130	160	193	25	13	33.5	63.5	96.5
100	121	147	180	203	30	5	31	64	87